

Spare parts list

INFORMATION:

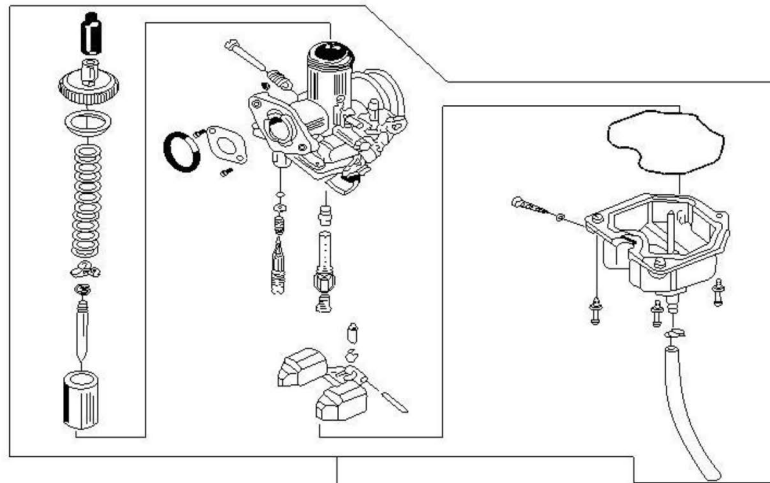

化油器
CARBURETOR

化油器 CARBURETOR

序号	件号	规格型号	英文名称	单位
No.	Part No.	Type	English Description	unit
1	301014117001	PZ19SZ-037be1_EPA(有JINGKE字样)	Carburator	P
1	301014011001	PZ19SZ-037b_适用于零下20度环境	Carburetor	P

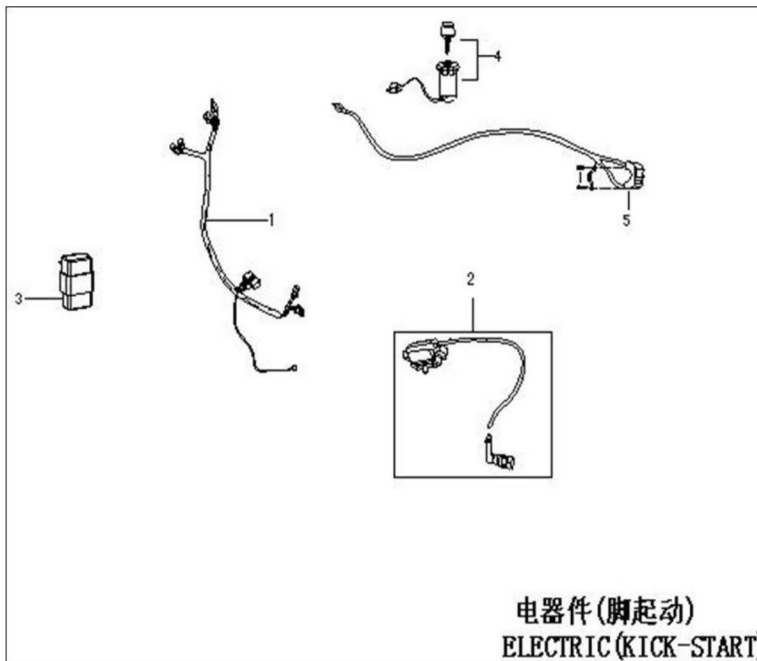

电器件(脚启动)
ELECTRIC (KICK-START)

电器件 ELECTRIC

序号	件号	规格型号	英文名称	单位
No.	Part No.	Type	English Description	unit
1	315007004001	21-脚-带电门锁_地线450	HARNESS (KICK-START)	P
2	315003004002	易力屏蔽高压包_12V-2.8插片2孔插	COIL ASSY, IGNITION	P

3	315001042001	进角点火器	CDI ASSY.	P
4	316008007001	四线二档(通用)	IGNITION KEY ASSY	SET
5	316004005001	全包型熄火开关-线长850mm	STOP SWITCH ASSY(KICK-START)	P

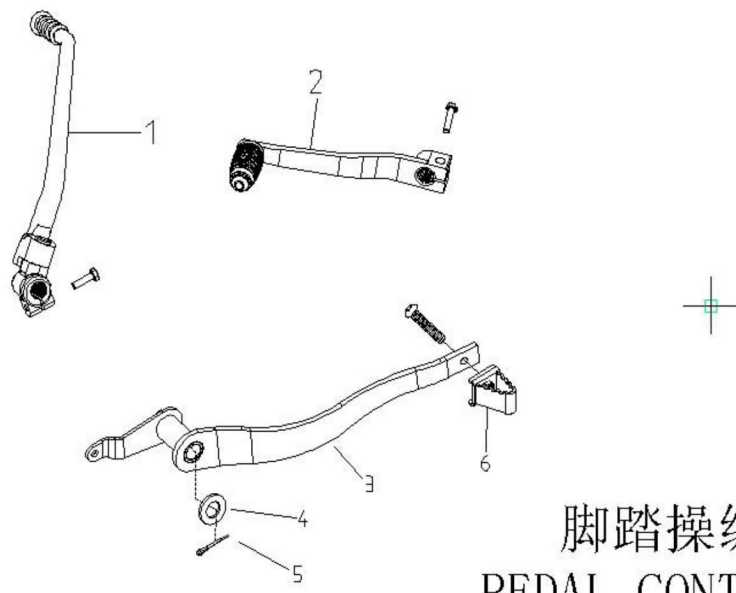

脚踏操纵件
PEDAL CONTROLLER

脚踏操纵件 PEDAL CONTROLLER

序号	件号	规格型号	英文名称	单位
No.	Part No.	Type	English Description	unit
1	301004008001	49#_φ13mm轴孔	Starter Lever(Steel)	P
2	301001012001	67-3#	Gear Lever	P
3	310031007004	34-2_无杆头	Foot Brake Lever	P
	310032001002	21G		P
	401001007001	M6X16mm_8.8级(GB/T 5789)		
4	405006017001	φ14Xφ25X1.5	WASHER	P
5	407005006002	φ2.5X40mm(GB/T 91-2000)	SPLIT PIN	P
6	310032001002	21G	Foot Brake Lever tip	P

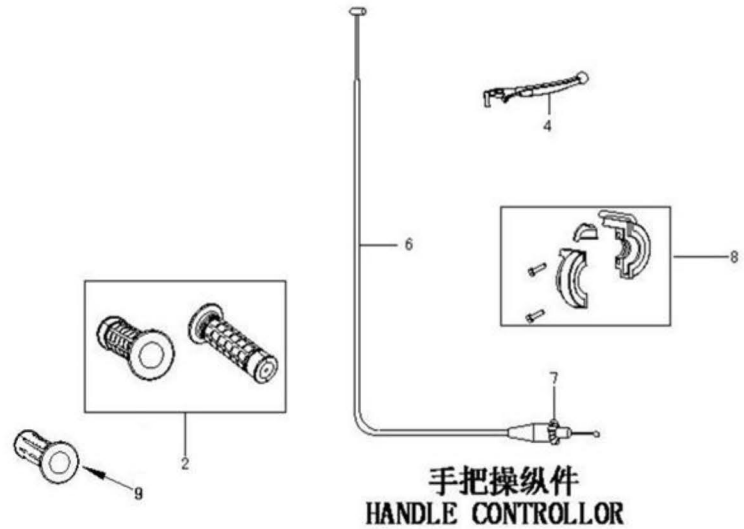

手把操纵件
HANDLE CONTROLLER

手把操纵件 HANDLE CONTROLLER

序号	件号	规格型号	英文名称	单位
No.	Part No.	Type	English Description	unit
2	310003014006	AM款_弹性体TPE	GRIP ASSY.	S
	310006001001	APL-1	GRIP CORE	P

4	310011002003	21D-铝-不可折叠	BRAKE LEVER	P
6	310013012001	长670mm_露110mm_配铁螺母	THROTTLE CABLE	P
8	310007001001	APL-1_铝	HOLDER ASSY,THROTTLE	S
	310017101001	APL-1		
	403004018004	M6X25mm_4.8级 (GB/T70. 2)		
9	310006001001	APL-1	INNER CORE OF THROTTLE GRIP	P

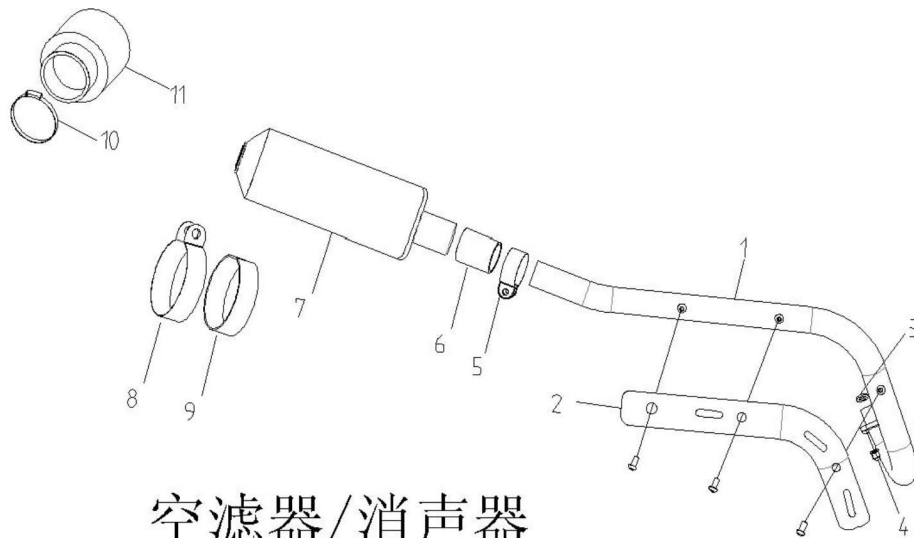

空滤器/消声器 AIR FILTER/MUFFLER

空滤器/消声器 AIR FILTER/MUFFLER

序号	件号	规格型号	英文名称	单位
No.	Part No.	Type	English Description	unit
1	302001021001	34-2C_铁_配CRF50塑件_排气管镀铬	Exhaust Assy.	SET
2	302006011001	配RFZ 34-2 (37CRF防烫片加工缩短)	The Protector for Exhaust Pipe	P
3	302004001001	50. 70. 110. 125. 140CC(Φ24XΦ31.5)	Exhaust Pipe Seal	P
4	404008004001	M6X22mm(GB/T 923)	Triple Clamp Top Nut	P
5	302008004001	宽度20mm, 安装孔Φ8, 配38mm~40	HOOP	P
6	302005002001	A37TTR-2/37TTR-2A/A37CRF-2_Φ35	INNER SEAL	P
7	302003043001	34-2_配RFZ塑件_KTM消声器无火花消	MUFFLER	P
8	302008009001	34-2_KTM消声器_无支柱	HOOP	P
9	302012001001	34-2_KTM消声器	HOOP RUBBER	P
10	301034003001	32-44_同舟	air cleaner hoop	P
11	301021017001	铁丝网-口径35mm-带补气嘴_EPA(打	Air Filter Assembly	P

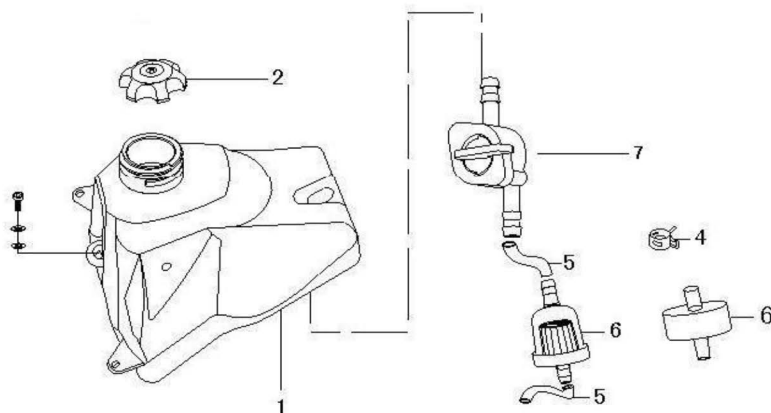

油箱/油开关 FUEL TANK/FUEL COCK

油箱/油开关 FUEL TANK/FUEL COCK

序号	件号	规格型号	英文名称	单位
No.	Part No.	Type	English Description	unit
1	312001065001	37-5_铁油箱_阿波罗公司打码Y-36-01050	FUEL TANK	P
2	312002017001	37CRF_油箱盖EPA(打码Y-36-01050100)	FUEL CAP	P
4	318001022001	φ 8X8X0.8	HOSE CLAMP	P
5	312004003002	φ 4.5X φ 8.5(单位:米)	FUEL HOSE	Kg
6	312003005001	塑料_黄色纸芯式	FUEL FILTER	P
7	312005005001	29	pet cock	P

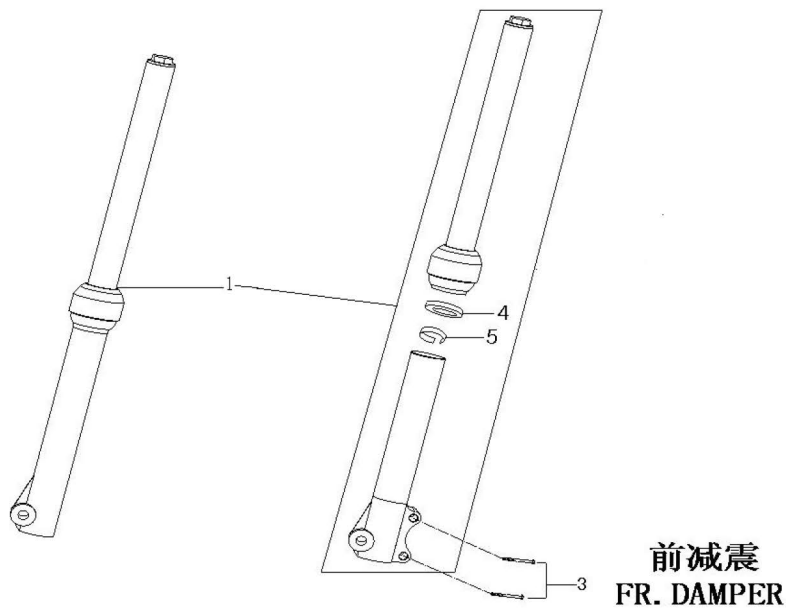

前减震 FR.DAMPER

序号	件号	规格型号	英文名称	单位
No.	Part No.	Type	English Description	unit
1	305001053001	34-2C_顺置_总长625mm_管径φ 33mm	Front Forks(M12Axes)	SET
3	401001056001	M8X35mm_8.8级(GB/T 5789)_耐落胶	FORK PROTECTIVE COVER	S
4	305009001001	不可调减震_33X46X11	OIL SEAL	s
5	305008001001	21FG_顺630_φ 33X46X11	Dust cover	S

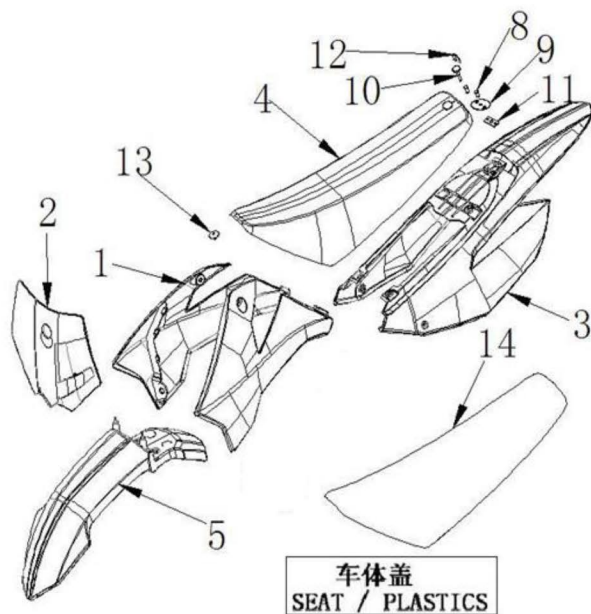

车体盖 SEAT / PLASTICS

序号	件号	规格型号	英文名称	单位
----	----	------	------	----

No.	Part No.	Type	English Description	unit
1	304001012010	37-5	L&R.F.SIDE COVER	S
2	304013002001	37-5_配21FG上连接板_上固定座位置	FRONT NUMBER PLATE	P
	403013018001	M5X16mm 4.8级 (GB/T818-2000)	bolt	
	404001005001	M8_要求S=12mm (GB/T 6170)	nut	
3	304009010005	37-5	REAR FENDER	P
4&8&9&10&11&12	313001068004	RFZ_SC1款_ZD015-010_粗的缝制线	SEAT	P
	319011003002	37-5_φ6X13.5	SEAT LOCK BOLT	P
	303043001003	37-5_铁	washer	P
	319011002002	37-5_M6	bolt	P
	410001002001	37-3专用_φ6Xφ16X1	spring washer	P
	303044001002	37-5_铁	buckle	P
5	304015011001	A37-5	FRONT FENDER	P
8	319011003002	37-5_φ6X13.5	SEAT LOCK BOLT	P
9	303043001003	37-5_铁	washer	P
10	319011002002	37-5_M6	bolt	P
11	410001002001	37-3专用_φ6Xφ16X1	spring washer	P
12	303044001002	37-5_铁	buckle	P
13	319011004002	37-5_M6_图号AGB37-5-09010009	bolt	P

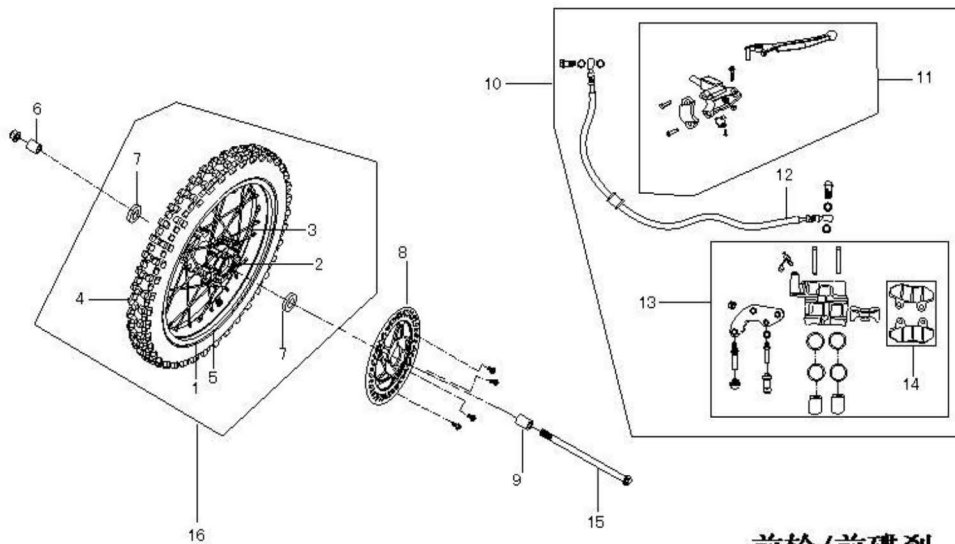

前轮/前碟刹
FT. WHEEL / BRAKE ASSY

前轮/前碟刹 FR.WHEEL/FR. BRAKE ASSY.

序号	件号	规格型号	英文名称	单位
No.	Part No.	Type	English Description	unit
1	307005009001	29轮胎_60/100-14(内胎60/100-14)	INNER TUBE 14"	P
2	307003017001	F-M14-1.4X14(广东款)_轮毂内衬套	Front Wheel Hub(Fe)	P
3	307013007001	14" _长153mm(铁,碟刹,广东款,含螺)	The Spoke for Front Wheel	P
3	307013004001	14" _长150mm(铁,碟刹,广东款,含螺)	The Spoke for Front Wheel	P
4	307005009001	29轮胎_60/100-14(内胎60/100-14)	Inner Tire	P
5	307009003001	14" _660X20X0.8	Tyre protective band	P
6	319001191001	φ15.5Xφ22X28mm	Spacer	P
7	409002033001	6202RS	OIL SEAL	P
8	308003049001	内孔φ76_外径φ190_圆盘_分布圆	FRONT-BRAKE DISK	P
9	319001184001	φ15.5Xφ22X19mm	Spacer	P
10	308001015001	34-2C_管长1020±3mm	FR.DISK BRAKE ASSY.	P
11	310011002003	21D-铝-不可折叠	FRONT BRAKE UPPER OIL PUMP(INCLUDE HANDLE)	P
12	308006015001	34-2_管长1060mm-两端10mm安装孔	FR,BRAKE HOSE	P
13	308007009001	34-2C/21F/21G_小双泵黑色(配21D碟)	FR,CALIPER ASSY.	P
14	308009002002	小A型(21、37CRF前碟刹及29前后摩)	FR, BRAKE PAD	S
15	401002075006	M14X1.5X215mm(轴φ15mm)_10.9级	Front Axle	SET

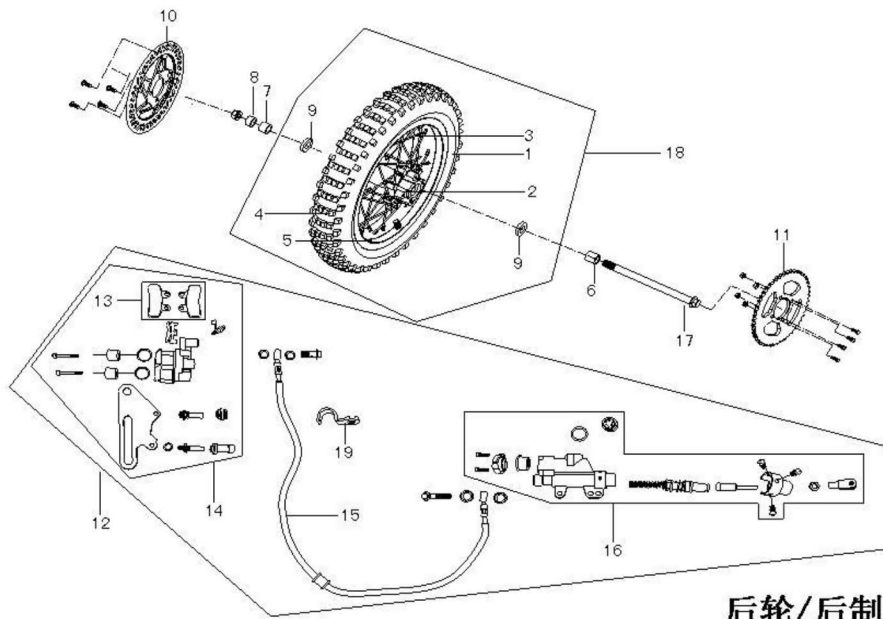

后轮/后制动器
RR. WHEEL/RR. BRAKE ASSY

后轮/后制动器 RR.WHEEL/RR. BRAKE ASSY.

序号	件号	规格型号	英文名称	单位
No.	Part No.	Type	English Description	unit
1	307005011001	29轮胎_80/100-12(内胎3.00-12)_G	INNER TUBE 12"	P
2	307004017004	F-M14-1.85X12(广东款)	RR.HUB 1.85×12 STEEL	P
3	307013105001	12" _长132mm(铁.碟刹.广东款.含螺	INNER SPOKE,RR.WHEEL 12"	P
3	307013103001	12" _长129mm(铁.碟刹.广东款.含螺	INNER SPOKE,RR.WHEEL 12"	P
4	307005011001	29轮胎_80/100-12(内胎3.00-12)_G	INNER TUBE 12"	P
5	307009002001	12" _660X20X0.8	INNER TUBE PROTECTOR	P
6	319001195001	∅ 15.5X∅ 22X36mm	SPACER	P
7	319001186001	∅ 15.5X∅ 22X22mm	SPACER	P
9	409002033001	6202RS	OIL SEAL	S
10	308004013001	37CRF-Y∅ 76X∅ 190	REAR-DISC	P
11	311003036004	定位直径76mm 428-41T_铁_(淬火处	REAR SPROCKET	P
12	308003061001	34-2_管长380±3mm_大单泵_L1=40,	REAR BRAKE ASSY	S
13	308009006002	37CRF 单泵后碟刹	RR.BRAKE PAD SET	S
14	308007107001	34-2款-带支架	RR,CALIPER ASSY.	P
15	308006111002	34-2_管长380±3mm黑色定型管长15	RR.BRAKE HOSE	P
16	308008013002	34-2_顶杆总长75mm	RR MASTER CYLINDER ASSY.	P
17	401002081001	M14X1.5X230mm_10.9级_带螺母(GB/	REAR-WHEEL AXLE	S
19	318001026002	APOLLO_材料ABS_16.5X125-∅ 6.6-5	VITTA CLIP WEDGE	P
	318017004001	定位孔直径92mm	REAR SPROCKET BOLT FIXER	P

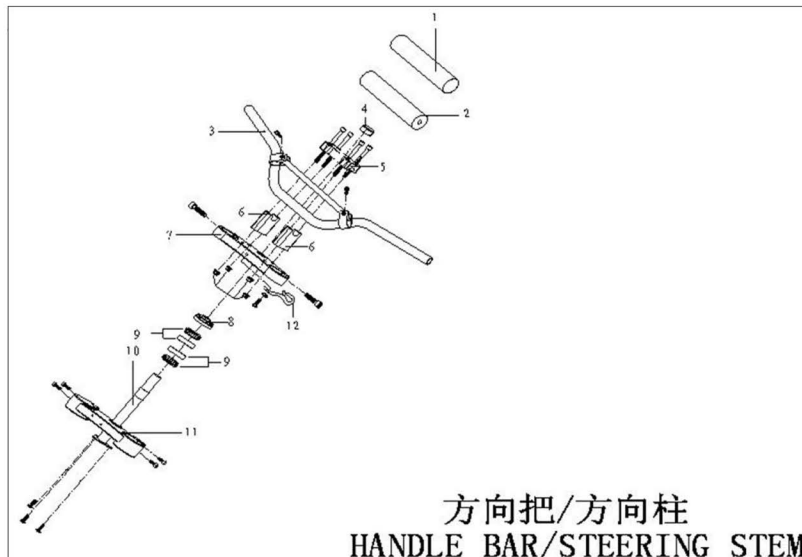

方向把/方向柱
HANDLE BAR/STEERING STEM

序号	件号	规格型号	英文名称	单位
No.	Part No.	Type	English Description	unit
1	320052080001	APLC-通用/APOLLO/233X175MM	CROSS BAR COVER	P
2	304035003001	38-2 (Φ 11XΦ 48X230mm)	CROSS BAR FOAM	P
3	404012001001	M22mm_厚度10mm	NUT STEERING UPPER M22	P
4	405006025001	Φ 22XΦ 36X1	WASHER (STEEL)	P
5	310020003008	29B_55mm_铝	HOULDER,HANDLE BAR	P
6	310001012004	34-2_铁_Φ 22_横杆上移_角度变更	HANDLE BAR STEEL	P
7	310019004004	29款_20mm_铝_配Φ 22管	TRIPLECLAMP	P
8	310021004004	21D_铝	UPPER TRIPLECLAMP	P
9	310024002001	M22_大锁母(M22X1XΦ 53盖内孔)	STEERING STEM LOCK NUT	P
10	409003004001	GB/T 297_32005_碳钢材质(d=Φ 25,	BEARING 32005	P
11	310022010002	34-2C_铝_方向柱安装孔直径25mm	TRIPLE CLAMP ASSY	P
12	310023010001	37-5_圆管内孔直径13mm_M22X1_长2	STEERING STEM ASSY	P

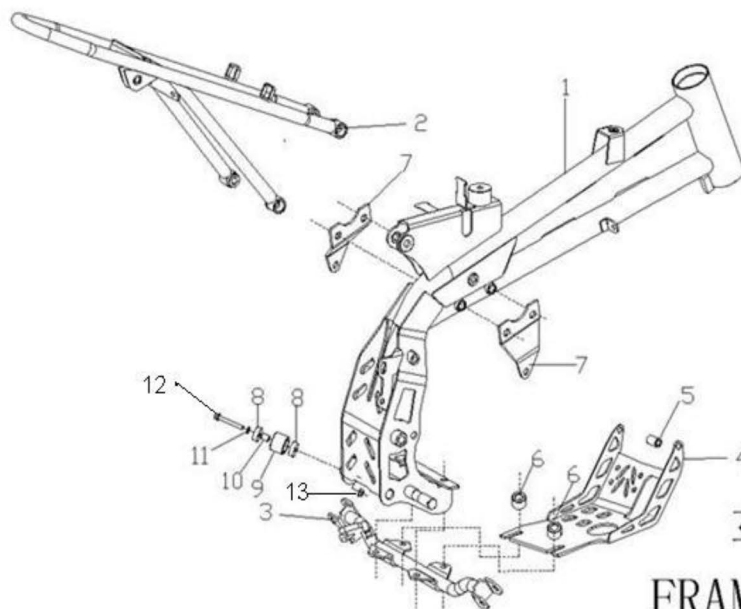

车架/尾架
FRAME/TAILSTOCK

车架 FRAME

序号	件号	规格型号	英文名称	单位
No.	Part No.	Type	Description	Unit
1	303001054005	34-2_配RFZ塑件_铁_带电门锁固定	FRAME	P
2	303006042001	34-2_配RFZ塑件_装油水分离器_铁	SUB-FRAME	P
3	303007019001	34-2_踏脚固定片一体式_铁	FOOT PEGS	P
4	303049003005	37-5_铁	ENGINE GUARD PLATE. STEEL	P
5	319001080002	Φ 7XΦ 16X20mm_铁	COLLAR	P
6	319001088002	Φ 8. 5XΦ 16X20mm_铁	COLLAR	P
7	303015005004	34-2	ENGINE BRACKET	P
8	409002023001	GB/T 276_608ZZ(d=8, D=22, B=7)	CHAIN ROLLER BEARING	P
9	311005001001	通用	CHAIN ROLLER (BOTTOM)	P
10	319001115001	Φ 9XΦ 12X12mm_铁	COLLAR	P
11	405003011002	Φ 8 (GB/T 93)	SPRING WASHER	P
12	401001036001	M8X1. 25X60-F_8. 8级 (GB/T5789)	bolt	P
13	404004002001	M8 (GB/T 6187. 1)	nut	P

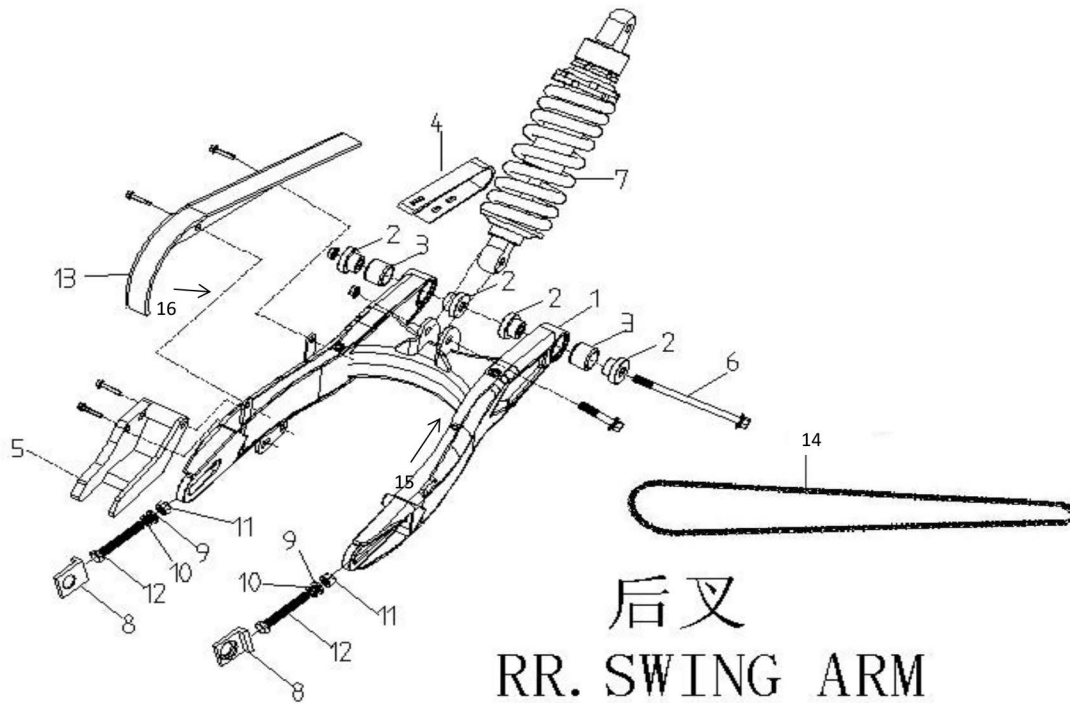

后叉
RR. SWING ARM

后叉 RR. SWINGARM

序号	件号	规格型号	英文名称	单位
No.	Part No.	Type	English Description	unit
1	306005071004	34-2_铁_KTM油管卡扣	REAR SWING ARM COMP	P
2	319002007001	∅ 10. 5X ∅ 29. 5X16mm(台阶 ∅ 20X10m	STEP BUSH	P
3	409001006001	GB/T 290_HK2020(Fw=20, D=26, B=20	NEEDLE BEARING HK1612	P
4	304034004001	37-5	REAR FORK DUST COVER	P
5	306007005006	37-5_铁后叉	CHAIN GUIDE-BRACKET	P
6	401002081001	M14X1. 5X230mm_10. 9级_带螺母(GB/	MIDDLE AXLE BOLT	S
7	306001016001	34-2C_不可调280mm	REAR SHOCK	P
8	306006013001	37-5-铝-方形-∅ 15. 5mm-36X31mm	CHAIN TENSIONER	S
9	405006048001	∅ 8X ∅ 16X1. 6(GB/T 97. 1)	WASHER	P
10	405003011002	∅ 8(GB/T 93)	SPRING WASHER	P
11	404001005001	M8_要求S=12mm(GB/T 6170)	NUT	
12	401003012001	M8X60X1. 25_8. 8级_全螺纹(GB/T 57	BOLT	
13	304032001001	半包型	CHAIN COVER	P
14	311001011001	428H-102节_SFR	CHAIN 428×110	P
15	401001004001	M10X45X1. 25_8. 8级_耐落胶(GB/T57	Bolt	P
16	404005003001	M10X1. 25(GB/T 6187. 2)	nut	P

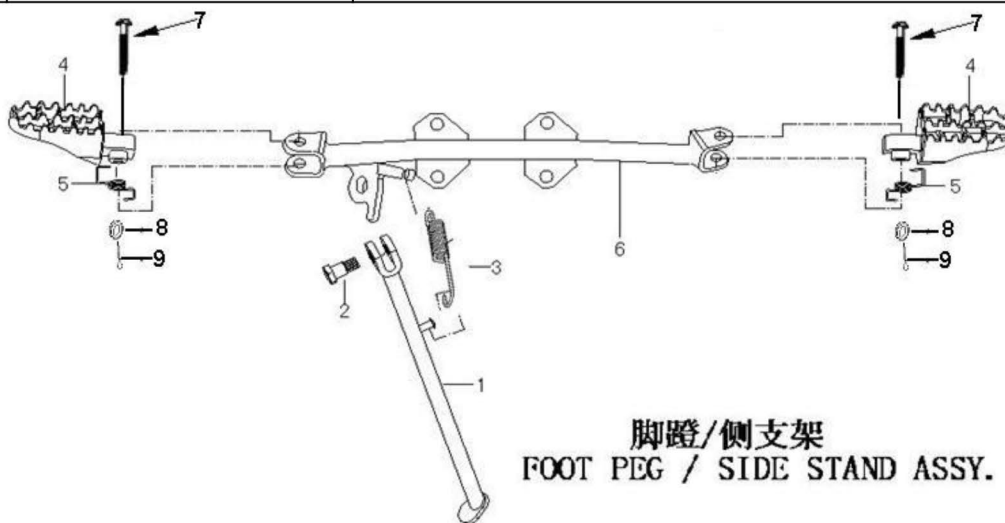

脚踏/侧支架
FOOT PEG / SIDE STAND ASSY.

脚蹬/侧支架 FOOT PEGS / SIDE STAND

序号	件号	规格型号	英文名称	单位
No.	Part No.	Type	English Description	unit
1	303012014004	34-2_310mm(开档6.5)	Kick Stand	P
2	319011017001	M10X24.5mmX1.25(台阶 ϕ 12X12.5mm)	Kick Stand Bolt	P
3	319007026001	115mm	Kick Stand Spring	P
4&5&7& 8&9	303010003002	37-5_安装孔为 ϕ 8.2mm_安装头部开	Foot Pegs	SET
	319007012001	37-5_3圈_内径 ϕ 18mm_弹簧钢丝直	SPRING, FOOT PEGS	P
	407006002002	ϕ 8X38mm-孔位34 (GB/T882-1986)	Foot Pegs	SET
	405006048001	ϕ 8X ϕ 16X1.6(GB/T 97.1)	SPRING, FOOT PEGS	P
	407005006002	ϕ 2.5X40mm(GB/T 91-2000)	FOOT PEGS	P
6	303007019001	34-2_踏脚固定片一体式_铁	FOOT PEGS	P