

目录 Index

1	车架 Frame
2	前悬挂 Front Suspension
3	后悬挂 Rear Suspension
4	车轮 wheel
5	制动器 Brake system
6	操纵转向机构 Steering control system
7	传动系统 Transmission parts
8	坐垫及塑件 Seat & Plactic Cover
9	货架 Handrail
10	电器 Electric system
11	照明信号 Light



车架 Frame



序号	Part NO.	Chinese Name	English Name	Spec	Unit
1	303001073001	主车架	frame_black	AGA-20E	pcs

前悬挂 Front Suspension



序号	Part NO.	Chinese Name	English Name	Spec	Unit
1	305018020003	摇臂	front swing arm	图号305018020000	pcs
2	305015021003	转向节左	left knuckle	图号305015021000	pcs
3	305015022003	转向节右	right knuckle	图号305015022000	pcs
4	409002021001	深沟球轴承	bearing	GB/T 276_6000RS (d=10, D=26, B=8)	pcs
5	319001291001	衬套	bush	∅ 10.5X∅ 14X34mm	pcs
6	305011005001	前减震	front shock	孔距180_弹簧直径∅ 6mm_中径∅ 35_安装孔∅ 10mm_黑弹簧白头	pcs

后悬挂 Rear Suspension

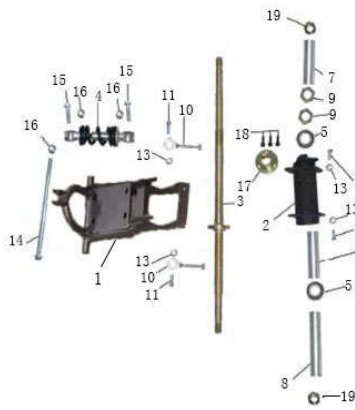

序号	Part NO.	Chinese Name	English Name	Spec	Unit
1	306005067001	后叉	rear swing arm	图号_306005067000	pcs
2	306012005001	后桥筒体	rear axle housing	碟刹状态_图号306012005000	pcs
3	306013006001	后桥轴	rear axle	长580mm_螺纹M14X1.5_焊接碟刹盘安装座_图号306013006001	pcs
4	306001074001	后减震	rear shock	孔距150_弹簧直径 \varnothing 7mm_安装孔 \varnothing 10mm_中径 \varnothing 45_黑弹簧白头	pcs
5	409002035001	深沟球轴承	bearing	6004 (RSD=42d=20B=12)	pcs
6	319001270001	衬套	bush	\varnothing 22X \varnothing 25X98.5mm_图319001270001	pcs
7	319001295001	衬套	bush	\varnothing 22X \varnothing 25X149mm	pcs
8	319001296001	衬套	bush	\varnothing 22X \varnothing 25X117mm	pcs
9	404002006001	1型六角螺母	nut	M20X1.5厚度8mm	个 pc
10	306006025001	千斤	chain adjuster	圆形_孔 \varnothing 9_有效螺纹M8X40_总长72mm	个 pc

车轮 wheel

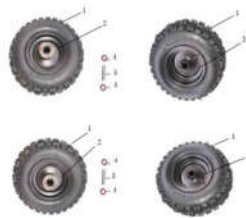

序号	Part NO.	Chinese Name	English Name	Spec	Unit
1	307005067001	轮胎	tire	4.10-6	pcs
2	307003050001	前轮毂	front rim	6寸带毂芯_黑色带红边	pcs
3	307003051001	后轮毂	rear rim	6寸带毂芯_带键槽_黑色带红边	pcs
4	409002022001	深沟球轴承	bearing	GB/T 276_6001RS (d=12, D=28, B=8)	pcs
5	319001289001	衬套	bush	\varnothing 12X \varnothing 16X64	pcs

制动器 Brake system

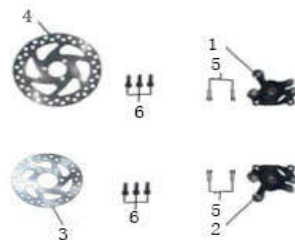

序号	Part NO.	Chinese Name	English Name	Spec	Unit
----	----------	--------------	--------------	------	------

1	309024001001	左制动钳	left caliper	M6螺纹孔距51_供应商名称:反制动钳	pcs
2	309024002001	右制动钳	right caliper	M6螺纹孔距51_供应商名称:反制动钳	pcs
3	308003048001	前碟刹盘	front brake disc	Φ120*2.0_固定中心孔Φ48_中孔Φ37_铁	pcs
4	308004032001	后制动盘	rear brake disc	外径Φ140*2.0_固定中心孔Φ40_内孔Φ29_铁	pcs

操纵转向机构 Steering control system

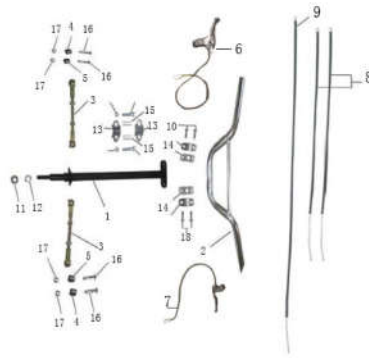

序号	Part NO.	Chinese Name	English Name	Spec	Unit
1	310023015001	方向柱	steering stem	AGA-20E_总长350mm	pcs
2	310001051001	方向把	handlebar	总长550±5mm_图号310001051001	pcs
3	305016007001	拉杆	pull rod	中连杆145mm(万向轴承)	pcs
4	319001292001	衬套	bush	Φ9XΦ11X5mm	pcs
5	319001293001	衬套	bush	Φ9XΦ11X8mm	pcs
6	310005006001	前刹手柄	front brake lever	圆头铝刹把(mini刹把)_双刹_驻刹_带刹车断电	pcs
7	310005008001	后刹手柄	rear brake lever	圆头铝刹把(mini刹把)_带刹车断电	pcs
8	310005005001	前刹线	front brake cable	圆头铝刹把(mini刹把)_双刹_驻刹(黑色)_拇指加速器	pcs
9	310005007001	后刹线	rear brake cable	圆头铝刹把(mini刹把)	pcs
13	310039002001	方向柱锁扣	steering stem holder	塑料(内孔Φ22)	pcs
14	310019019001	方向把卡座	handlebar holder	AGA-3_四件套_锁Φ22	pcs
15	319001294001	衬套	bush	Φ8.5XΦ14X39.5mm	pcs

传动系统 Transmission parts

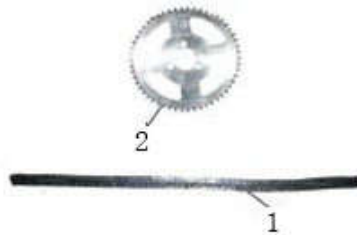

序号	Part NO.	Chinese Name	English Name	Spec	Unit
1	311001111001	链条	chain	T8F-84节	pcs
2	311003053001	后链轮	rear sprocket	T8F_68齿	pcs

坐垫及塑件 Seat & Plastic Cover



序号	Part NO.	Chinese Name	English Name	Spec	Unit
1	304060002003	车体塑件	body plastic	小金刚	pcs
2	606009002005	脚踏左	left footrest	小金刚	pcs
3	606009001005	脚踏右	right footrest	小金刚	pcs
4	601016007001	前保护面板	head plastic	小金刚	set
5	304045006001	前大灯罩	headlight guard	AGA-20E小金刚	set
6	313001015002	座垫	Normal seat	AGA-20_小金刚_普通座垫皮	pcs
	313001016001	RFZ 座垫	High quality skin seat	AGA-20款小金刚_荔枝纹	pcs
7	304062030001	链罩	chain cover	AGA-22_塑料	pcs

货架 Handrail



序号	Part NO.	Chinese Name	English Name	Spec	Unit
1	314004003001	后扶手	rear armrest	图号314004003000	pcs
2	601016008001	前保护面板支架	head plastic bracket	AGA-20E	pcs

电器 Electric system

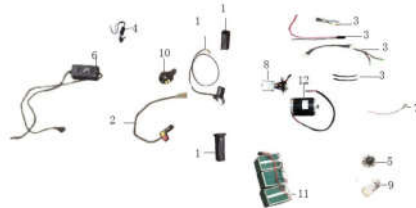

序号	Part NO.	Chinese Name	English Name	Spec	Unit
1	315037016001	霍尔转把	speed handle	带电量显示_带左右把套	pcs
2	316035001001	二功能开关	switch	喇叭_大灯	pcs
3	315007065001	主电缆	wiring	AGA-20E_带防小帽_全由油线(带绝缘帽)	pcs
4	316008007001	电门锁	ignition key	四线二档(通用)	pcs
5	315005005001	倒车继电器	gear switch	小小铃木电动(供应商凯伦机电)	pcs
6	315014023001	充电器	charger	36V2A圆形接口	pcs
7	315067002001	充电口	charger port	圆形接口两线(带防水盖)	pcs

	315031011001	控制器	controller for 500W	小小铃木电动YKABL03_36V_20A_500W	pcs
8	315021059001	控制器	controller for 800W	小小铃木电动YKABL03_36V_32A_800W	pcs
	315031012001	控制器	controller for 1000W	小小铃木电动YKABL03_36V_40A_1000W	pcs
9	316034001001	档位调节开关	speed switch	小小铃木电动	pcs
10	316009006001	电喇叭	horn	36V	pcs
11	315015013002	电池	battery	36V12AH_螺纹孔线柱(3个1组)	set
12	315031011001	电机	motor 36V 500W	36V500W (型号ZY1020)_小链轮T8F11齿	pcs
13	315031010001	电机	motor 36V 800W	小小铃木电动_36V800W (型号ZY1020)_小链轮T8F11齿	pcs
14	315031012001	电机	motor 36V 1000W	36V1000W (型号ZY1020)_小链轮T8F11齿	pcs

照明信号 Light



序号	Part NO.	Chinese Name	English Name	Spec	Unit
1	316013036001	前大灯_本色	headlamp with light	LED (36V)	set